



GENESIS Heating Mantle

Temperature Controller Instruction Manual

Version 1.1 (January, 2023)

Input type	Thermocouple (TC): K RTD (Resistance Temperature Detector): Pt1000
Input range	K type TC: -328 ~ 2372°F, or -200 ~ 1300°C Pt1000: -328 ~ 752°F, or -200 ~ 400°C
Accuracy	± 0.2% Full scale
Response time	0.5 s
Display resolution	1°C, 1°F
Control mode	PID control
Output mode	Relay contact: 1 A at 240 VAC, 3 A at 120 VAC, or 3 A at 24 V AC for resistive loads. DC output for SSR: 12 VDC / 30 mA
Alarm	Internal buzzer
Alarm function	Programmable Only
Power supply	85 V ~ 260 V AC / 50 ~ 60 Hz
Power consumption	5 Watt
Ambient temperature	0 ~ 50°C, 32 ~ 122°F
Dimension	96 x 48 x 90 mm (W x H x D), 1/8 DIN size
Mounting cutout	90 x 45 mm



GENESIS Program Cheat Sheet

PID adjust: Press & hold 'SET' -->166 -->'SET'

— Liquid — Jacket —

P: 30	P: 1	Do not adjust grayed out fields
I: 600	I: 0	
D: 0	D: 0	
AT: 0	AT: 0	
T: 2	T: 2	
R1: 1	R1: 1	
R2: 0	R2: 0	

System Config "Duty Change":
Press & hold 'SET' -->155 -->'SET'

— Liquid — Jacket —

SC1: 0	SC1: 5	Do not adjust grayed out fields
SC2: 0	SC2: 0	
OUT: 95	OUT: 10	
C-F: C	C-F: C	
Sn: Pt	Sn: Pt	
W2D: SV		

P: Window up to the set temp where PID stops 100% power function and begins accurate temp climb

I: Selected range of aggressive function to and within the P (window)- both in 100% ramp and P (window) control.

Higher number = Slower ramp
Lower number = Faster ramp

D: Dedicated digital heat repeat when temp is measured incline.

∅ = No function

1-9999 = Higher value = Faster reheat
Lower value = Lagging reheat

3. Front Panel and Operation



Figure 2. Front panel.

- ① Relay 1 (R1) output indicator. When it is on, R1 relay is activated
- ② Relay 2 (R2) output indicator. When it is on, R2 relay is activated.
- ③ PID control output indicator. It is synchronized with the control output (terminal 3 and 4) to the load.
- ④ Timer key. Toggle the bottom display window between the temperature of Probe 1 and the timer.
- ⑤ Increment key ▲. Increases the numeric value.
- ⑥ Decrement key ▼. Decreases the numeric value.
- ⑦ SET key. When it is pressed momentarily, this controller will enter temperature profile settings mode. See section 5 below for details. When pressed and held for two seconds, the controller will enter the parameter setting mode. See section 7 below for details.
- ⑧ Cabin temperature, top window. In normal operation mode, it displays the temperature reading from Probe 1. When the high or low limit alarm of Probe 1 is activated, this window will flash between the alarm type (AH1 or AL1) and the detected temperature. In the parameter setting mode, it displays the controller's system parameters.
- ⑨ Temperature/time, bottom window. In normal operation mode, it displays the temperature reading of Probe 2 (the probe of food internal temperature) or the time passed since the controller has been powered up. When the high limit alarm of Probe 2 is on, this window will flash between AH2 and the detected temperature. In the parameter setting mode, it displays the value of the parameter that is being shown in the top window.
- ⑩ Timer indicator. When the bottom display shows timer, the decimal point in the right bottom corner will be on.

4. Back Terminals and Wiring

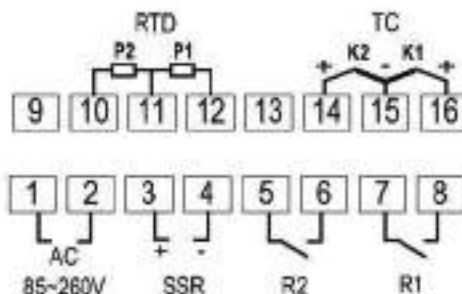

Figure 3. Back terminals.

4.1 Temperature Input

The Genesis controller accepts two types of sensors, PT1000 RTD sensor and type K thermocouple. Please refer to Table 3 for the input sensor type (Sn) setting codes. The controller can read from two sensors at the same time, but the two sensors must be in the same type. The initial setting for input is for a K type thermocouple. Set Sn to the correct sensor code if another sensor type is used.

RTD sensor

Only two-wire PT1000 sensors should be used. The Probe 1 should be connected to terminal 11 and 12 to read the smoker cabin temperature. The Probe 2 should be connected to terminal 10 and 11 to read the temperature.

Thermocouple

Only type K thermocouples are accepted. The Probe 1 should be connected to terminal 16 and 15, with the positive wire on terminal 16. The Probe 2 should be connected terminal 14 and 15, with the positive wire on terminal 14. There are two commonly used color codes for type K thermocouple. US color code uses yellow (positive) and red (negative). Imported DIN color code uses red (positive) and green/blue (negative). The temperature reading will decrease as temperature increases if the polarity is reversed.

4.2 Power to the controller

The controller accepts 85-260V AC power. The power cables should be connected to terminal 1 and 2. Polarity does not matter. For the sake of consistency with the wiring example described later, we suggest you connect the hot wire to terminal 1 and neutral to 2.

4.3 Control Output

This controller has three output ports, one port for SSRs and two relay output ports. The SSR control output (terminal 4 and 5) of this controller provides a 12V DC signal that can control up to 5 SSRs in parallel. The relay outputs of the controller (R1 and R2) can be used to control contactors or solenoid valves. The relay is rated for 10 Ampere current under 120VAC, which can be used to drive a small heater directly. For applications that need extra control outputs, such as one for second location and another for cooling shower, relays R1 or R2 can be used as two time or food temperature related control output.

4.4 Notes to users without prior experience with PID controllers.

The following notes may prevent you from making common mistakes.

4.4.1 Power to the heater does not flow through terminal 1 and 2 of the controller. The controller itself consumes less than 2 watts of power. It only provides a control signal to the relay. Therefore, wires from 18 AWG to 26 AWG range should be used for providing power to terminals 1 and 2. Thicker wires may be more difficult to install.

4.4.2 The relay output R1 and R2, are dry single pole switches. They do not provide power by themselves. Please see Section 13 for how they are wired when providing a 120V output (or when output voltage is the same as the power source for the controller).

4.4.3 The SSR output power does not come from the input of the SSR. The output of the SSR is a single pole switch between terminals 1 and 2 of Auber's SSR. The input of the SSR is for controlling, or triggering the SSR. (Please

note we are talking about the SSR itself, not the control output for SSR from the controller). When switching a North American 240 VAC power connected to a heater, the heater will be live even when the SSR is off. The user should install a double pole mechanical switch to the power input.

4.4.4. The power is controlled by regulating the duration of the on time for a fixed period of time. It is not controlled by regulating amplitude of the voltage or current. This is often referred as time proportional control. For instance, if the cycle rate is set for 100 seconds, a 60% output means controller will switch on the power for 60 seconds and off for 40 seconds (60 / 100 = 60%). Almost all high-power control systems use time proportional control because amplitude proportional control is too expensive and inefficient.

5. Programming the Temperature Profile

A total of 6 steps can be programmed on this controller. Each step contains the set temperature (C-X) and an ending criterion setting (E-X), where "X" is the step number. For example, the Step 4 temperature is represented by C-4 and the Step 4 ending criterion is represented by E-4. The ending criterion determines how does controller finish the current step and start the next step. There are two options for the user, t and F. Set E-X to t if you want step X to be end by a preset time. Set E-X to "F" if you want step X to end by a preset temperature of the internal probe.

After you set E-X to "t", you will be asked to set t-X for the time. Time is defined as the duration between the last step and the next step. Please make sure the time is long enough for the heater to heat up the device. If the time is set too short, the temperature may not be able to reach the current step temperature setting, before it jumps to the next step. The time unit is in minutes with 1 minute resolution.

If you set E-X to F, you will be asked to set F-X for the temperature of the internal probe. When all of the E-X are set to t, the controller can operate with only the probe 1 plugged in.

To program the temperature profile, press SET key once. The display will show C-1 at the bottom window and temperature setting on the top window for step 1. Use "▲" and "▼" keys to change the setting. When finished, press the SET again to confirm the change. The display will show E-1 on the bottom window and the ending criterion setting on the top window. Use "▲" and "▼" keys to change the setting. When finished, press the SET again to confirm the change. The bottom window will display t-1 or F-1 depending whether t or F is selected for the E-1. The top window will display the setting for t-1 or F-1. Use "▲" and "▼" keys to change the setting. When finished, press the SET again to confirm the change. The display will go the step 2 setting. It will repeat in the same way as the step 1. After you program enough step for the recipe, you can program rest of the steps of E-X to t and set t-X zero.

The temperature setting will not be changed if SET is not pressed (confirmed). After programming the necessary steps for heating, you can finish programming by pressing the SET continuously until it passed T-6 and display the current temperature. You can also leave the controller alone. The display will return to the normal display mode if no key is pressed within 15 seconds. The initial program setting for the controller is listed in Table 1. This program will control the temperature of the cabinet at 120 °F for 120 minutes. Then, change the temperature to 190 °F. It will stay at 190 °F until internal temperature of the heating reaches 160 °F. Then, the controller will drop the temperature to 130 °F for 5 hours (300 minutes), waiting you to reset system. If

you set C-3 = 0 and t-3 = 0, when meat internal temperature reaches 160 °F, the controller will shut off the heater, flashing END on both windows, and turn on the beeping alarm to notify you that heating is finished.

Table 1. Initial program setting

Step #	Temp (°F)	Step #	F or T	Step #	Value
C-1	120	E-1	t	t-1	120
C-2	190	E-2	F	F-2	160
C-3	130	E-3	t	t-3	300
C-4	0	E-4	t	t-4	0
C-5	0	E-5	t	t-5	0
C-6	0	E-6	t	t-6	0

This controller has two relay outputs (R1 and R2). One relay can be used for the second location, the other one can be used for a cooling device. You can activate the relay in one of 6 program steps. Please check Section 10 for details.

These two relays are controlled by parameter R1 and R2 that can be accessed by code 166 (see Table 2). The parameter R1 specify at which step the relay R1 should be pulled in; the parameter R2 specify at which step the relay R2 should be pulled in. For example, to turn on the second location connected at step 1, set R1 = 1; to turn on the cooling device at step 6, set R2 = 6.

6. Check the Current Step and Display the Time

To check which step the program is at during cooking, press the "▲" key once. The top window will show the current step in the form of P-X. For instance, it will display P-3 if the controller is at step 3. The display will automatically return to the temperature display mode after 8 seconds. To check how long the controller has been running since powered up, press the Time key once. The bottom window will show the actual time passed since the controller was powered up. Please note that this is the total time, not the time passed in the current step. Press Time key again to switch back to internal temperature.

7. Control Parameters

The control parameters are divided into three groups.

7.1 Control Parameters (Code 166)

They need to be adjusted based on the system to be controlled. Table 2 shows the list of these parameters, their range and initial set value when left the factory.

Table 2. List of parameters and its initial settings under code 166.

Symbol	Display	Description	Range	Initial
P	P	Proportional band (in 1 degree)	0 - 9999	7
I	I	Integral constant (second)	0 - 9999	600
D	D	Derivative constant (second)	0 - 9999	150
AT	At	Auto-tune	0 = off, 1 = on	0
T	t	Cycle rate (second)	2 - 9999	2
R1	r 1	Turn-on step of relay R1	0 - 6	1

R2	r ²	Turn-on step of relay R2	0-6	0
----	----------------	--------------------------	-----	---

Details about every parameter.

- P. Proportional band.** Its unit is 1 degree. This parameter controls the output of the controller based on the difference between the measured and set temperature. Larger the P number means the weaker the action (lower gain). If P = 7, the proportional band is 7 degrees. When the sensor temperature is 7 degrees below the proportional band (10 degrees below the setting), the controller will have 100% output. When the temperature is 5 degrees below the set point, the output is 71%. When the temperature is equal to the setting, the controller will have 0% output (assuming integral and derivative functions are turned off). This constant also affects both integral and derivative action. Smaller P values will make the both integral and derivative action stronger. Please note the value of the P is temperature unit sensitive. If you found an optimized P value when operating the controller in Fahrenheit, you need to divide the P by 1.8 when changing the temperature unit to Celsius.
- I. Integral time.** The unit is in seconds. This parameter controls the output of controller based on the difference between the measured and set temperature integrated with time. Integral action is used to eliminate temperature offset. Larger number means slower action. e. g. assuming the difference between the measured and set temperature is 2 degrees and remain unchanged, the output will increase continuously with time until it reaches 100%. When temperature fluctuate regularly (system oscillating), increase the integral time. Decrease it if the controller is taking too long to eliminate the temperature offset. When I = 0, the system becomes a PD controller. For very slow response system, set I = 0 will significantly reduce the temperature overshoot.
- d. Derivative time.** The unit is in seconds. Derivative action contributes the output power based on the rate of temperature change. Derivative action can be used to minimize the temperature overshoot by responding its rate of change. The larger the number is, the faster the action will be. For example, when the door of oven is opened, the temperature will drop at very high rate. The derivative action changes the controller output based on the rate of change rather than the net amount of change. This will allow the controller to act sooner. It will turn the heater to full power before the temperature drops too much.
- AT. Auto-tune function.** Set AT to 1 then exit the menu. The display will start to flash alternately between AT and the current temperature, which indicates auto-tuning is in progress. When the display stops flashing, the auto-tuning is finished. Now, the newly calculated PID parameters are set and are used for the system. The new parameters will store in the memory even the power is off. For more information about auto-tune, please see section 8.
- T. Cycle rate.** The unit is second. This unit determines how long for the controller to calculate each action, i.e., if T is set to 10 seconds, when controller decide the output should be 10%, it will turn on the heater 1 second for every 10 seconds. This parameter should set at 2 second for electric heater switched by SSR.
- R1 and R2. Relay Output Definition.** Those two parameters determine which steps to turn on Relay 1 and/or Relay 2. For example, to turn on Relay 1 at

step 1, R1 needs to be set to "1". To turn on Relay 2 at step 6, R2 needs to be set to "6".

The flow chart in Figure 5 shows how these parameters can be changed. Press and hold SET key for 4 seconds until LED display "LOCK" on the bottom window, then release the SET key. The display on the top window will show "0". To get into parameters setting mode, you need to key in the pass code. Use "▲" and "▼" keys to adjust the display to 166 (which is the passcode) and press SET. The bottom window will display "P" and top window is P setting value. Use "▲" and "▼" keys to change the setting. When finished, press the SET again to confirm the change. The bottom display will show the "I" right window has its setting value, use the same "P" setting procedure to set the I value. The rest of parameters are set in the same way.

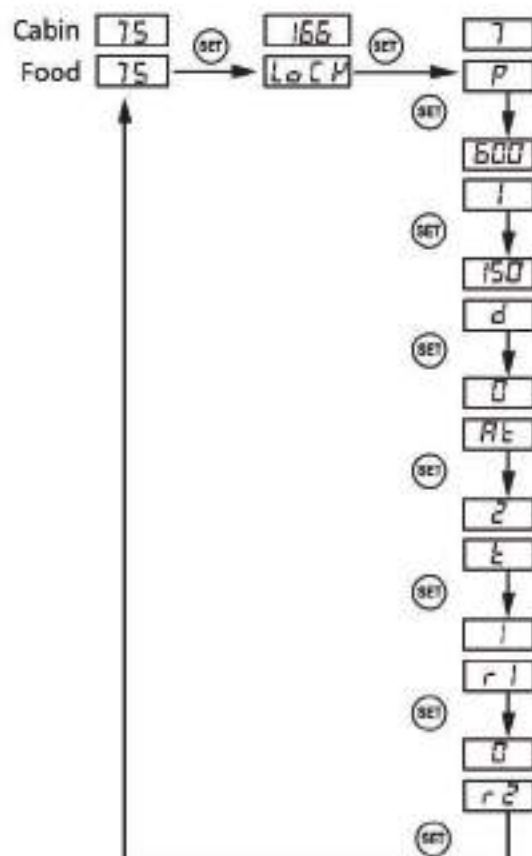

Figure 5. Code 166 Parameter setup flow chart.

7.2 System Configuration Parameters (Code 155).

Once they are set, they normally do not need to be changed. This group of parameters can be accessed by input code 155. If you don't want your system to be altered by other person, do not let other people know this code. Table 1 show the list of the parameters, their range and initial set value when left the factory.

Table 3. List of parameters and its initial settings under code 155.

Symbol	Display	Description	Range	Initial
SC1	5 C 1	Sensor 1 offset (in degree)	-40~+40	0
SC2	5 C 2	Sensor 2 offset (in degree)	-20~+40	0
Out	o u t	Output power (%)	0-100	100
C-F	C -F	Temperature unit	*C or *F	*F
Sn	S n	Sensor type	PT, K	Pt
W2D	W 2 d	Window 2 display mode*	Fd, SV	Fd

Note *, W2D is a new parameter added to SMD-200B. It is not available in SMD-200A or older versions.

Details about each parameter.

- **SC1/SC2**, calibration offset. The parameter is used to make the input offset to compensate the error produced by sensor. For example, if the temperature displays of top window is 2.0 °C in ice water mixture, set SC1 = -2.0 will make the display to show 0.0 degree. SC1 is for the control temperature probe (Probe 1). SC2 is for the internal temperature probe (Probe 2).
- **Out**, Output power percentage. It is expressed as a percentage value. This function will allow you to control the maximum output power delivered by the heater. For example, if you set Out = 50 and your heater is 1000 watts, the output will use 50% of the 1000 watts as the full output. It thinks the 1000W heater as a 500W heater. When the PID algorithm determines 50% output value, the actual power output will be 250 watts. This function can be used in two situations.
 - 1) When you have a very powerful heater and using a very small pot of water to cook at very low temperature, for example, a 1400 watts heater with a one liter (1 qt) pot of water at 130 °F. The heater is too powerful for the small water volume. The moment it is on, it releases too much energy to cause the temperature to overshoot. Although it is still possible to stabilize the temperature with proper PID parameters, it is much easier to control if you limit the maximum output to 25%. Ideally, an optimized temperature control system should consume about 25 % of the heater power at set temperature (steady state), for example, if you found out that only 50 watts of energy is needed to maintain the temperature at 60 °C (141 °F), ideally you should use only 200 watts heater for the job. Too much power will make the system over react too quickly. Too little power will make the system too slow in response. By using the Out function, you can make the 1400 watts heater to act as a 200 watt heater for stable temperature control.
 - 2) When the load consumes more power than controller can handle, for example, if you have a cooker with a 12A, 120V AC heating element and it contains more than 38 liters (10 gallon) of water. It might take more than 90 minutes of full power heating for controller to heat up the pot. Long time of full power operation might cause the controller to overheat. You can set the output to 80%. It will prevent the controller from over heat by staying a full power too long. For details, please see Appendix 1.
- **C-F**, temperature unit. You can set the display either Celsius or Fahrenheit.
- **Sn**, Input sensor type setting. You can change the input sensor type between PT (RTD, PT1000) and K (K type thermocouple). Note, this controller can only use PT1000 RTD sensor or K type thermocouple sensor at same time. It cannot read one PT1000 and one K type thermocouple at same time.
- **W2D**, Window 2 display mode. The second window on the controller can be used to either display the temperature reading from the probe or to display the Set Value of the current set step. By default, the W2D is set to "Fd" for display of the probe reading. When W2D is set to "SV",

the second window will show the Set Value.

This group of parameters is accessed by input code 155. Figure 6 is the flow chart that shows how they can be changed. Press and hold SET key for 4 second until bottom window displayed "LOCK". Release the SET. The right window will show "0". Use "+" and "-" keys to adjust the display to 155 (another pass code) and press SET. The bottom window will show the parameter and top window will show its value. Use "▲" and "▼" keys to change the setting. When finished, press the SET to confirm the change. The next parameter will be displayed.

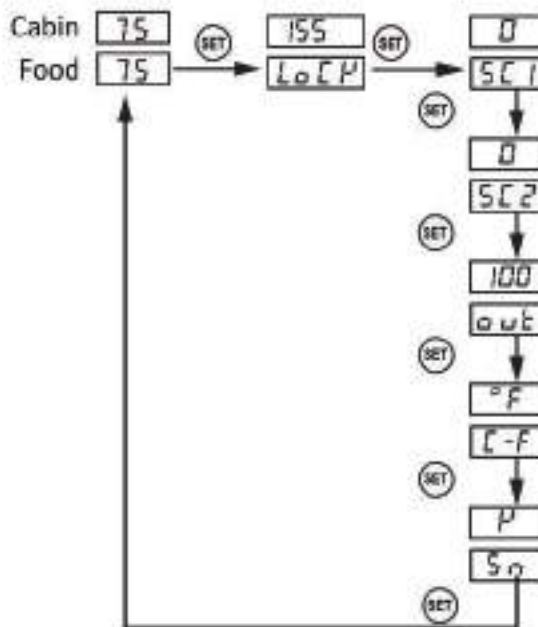

Figure 6. Code 155 Parameter setup flow chart.

7.3 Alarm Settings (Code 188).

The alarm setting can be accessed by code 188. Table 4 shows the list of the parameters, their range and initial set value when left the factory.

Table 4. List of parameters and its initial settings under code 188.

Symbol	Description	Range	Initial
AH1	Probe 1 high limit alarm	-99 – max. input range*	290
AL1	Probe 1 low limit alarm	-99 – max. input range	0
AH2	Probe 2 high limit alarm	-99 – max. input range	200
AST	Step finish alarm	On, OFF	ON

Note *, For type K thermocouple, the maximum input range is 2372°F or 1300°C. For PT1000 RTD, the maximum input range is 752°F or 400°C.

Details of each parameter.

- **AH1**, this is the high limit alarm for probe 1. User can set the temperature so that if the system is out of control, the buzzer will be turned on. e.g., if AH1 set to 290, the buzzer will be on at 291 and off at 290. When the buzzer is on, the top window will flash AH1 and the current temperature. To disable AH1 alarm, you can set it to a large number, like 350.

- **AL1** is the low limit alarm for probe 1. If AL1 is set to 100. The buzzer will be on when temperature drop to 100. It will be turned off when temperature rise to 101. This alarm is suppressed when first powered up. It will only function after the temperature has reached set point once. When the buzzer is on, the top window will flash AL1 and the current temperature. To disable AL1 alarm, you can set it to a small number, like 0 (default).
- **AH2** is the high limit alarm for the probe 2. If AH2 set to 190, the buzzer will be on at 191 and off at 190. When the buzzer is on, the right window will flash AH2 and the current temperature. When smoking multiple pieces of meat with different thickness, you can put the probe in the thinnest piece first. Set the alarm to the temperature when meat is ready. It will let you know when it is done. Then, you can move the probe to the second thinnest pieces and so on. To use this feature, you can set the ending criteria to time. If you set ending criteria to temperature, you need to set the ending temperature to be higher than the alarm temperature. To disable AH2 alarm, you can set it to a large number, like 350.
- **AST** is the step ending alarm. When AST is turned on, the buzzer will beep 4 times when each step is finished. It is useful to notify the user the heating step is finished. User can turn it off if no buzzer sound is wanted at the finish of each step.

Note: All alarm can be muted during beeping by pressing the "▼" key.

This group of parameters is accessed by input code 188. The flow chart is shown in Figure 7. Press and hold SET key for 4 second until bottom window displayed "LOCK". Release the SET. The right window will show "0". Use "▲" and "▼" keys to adjust the display to 188 (passcode) and press SET. The bottom window will show the parameter and top window will show its value. Use "▲" and "▼" keys to change the setting. When finished, press the SET to confirm the change. The next parameter will be displayed.

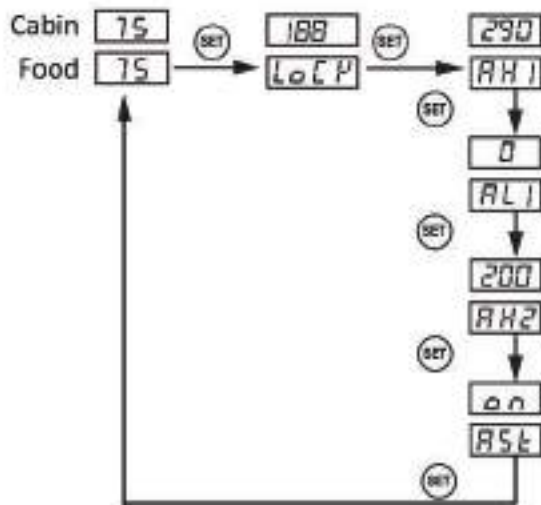

Figure 7. Code 188 Parameter setup flow chart

8. Auto-Tune

The default *P*, *I* and *D* setting of the controller was optimized for the Genesis Mantle through extensive manual tuning. We found these group of setting works for most smokers on the market. In many cases, it works better than the

setting obtained via auto-tune. We suggest the user to try the default setting first. If you don't like the result, you can try to increase the *P* value if your system heats up too fast, or decrease the *P* if your system heats up too slow. The values of parameter *I* and *d* can be left as the default because more of the heat respond similarly. If you don't like the result and does not want to manual tune it, you can run the auto-tune.

Every type of PID has its own unique set of tuning parameters. For the controller to heat with stability, it must have programmed with the tuning parameters for the heat currently being used.

When Should the Controller be Tuned?

If the PID parameters we provided are not working for your liking, you can use the auto-tuning function to let the controller to determine the PID parameters automatically. Auto-tuning function (it's often known as self-tuning) can automatically optimize the PID parameters for your chosen heating system. The auto-tuning function will heat up your smoker then let it cool down. It will repeat this heat/cool cycle several times. Based on the response time of the whole heating system, the controller will calculate and set the PID parameters for your heater.

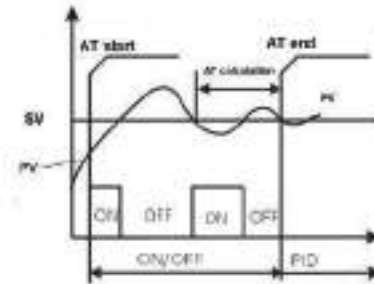

Figure 8. Auto-tune

Before using the auto-tune function, you must set the heating equipment up in the exact configuration it will be used. If the heater has its own thermostat or power control, turn both as high as they'll go. Set the controller to the appropriate power level. Turn the controller on, and then enter the desired set point temperature closed to your normal heating ramp temperature.

To activate auto-tuning, just enter code 166 to get into the PID setting menu. Set *At* = 1 then exit the menu (see Figure 5). The display will start to flash alternately between AT and the current water bath temperature, which indicates auto-tuning is in progress. When the display stops flashing, the auto-tuning is finished. Now, the newly calculated PID parameters are set and are used for the system. The new parameters will store in the memory even the power is off.

You should always write down your old PID parameters before starting auto-tuning. This way if something goes wrong, you can always go back to your old PID parameters.

The duration of auto-tuning depends on how fast the system is responding to the heating and cooling cycle. If the temperature of the heater takes a long time to drop (when the heater is off), the auto-tuning could be a very long process. This is especially true with a well-insulated heater. But in general, the auto-tuning should be able to tune most of your chosen with fairly good result.

9. Save and Recall Recipes

General introduction for the recipe function for this controller.

This controller has two "memories" to store the programming steps. One is the current running "memory". This controller will run the programming steps from this running "memory", like C-1, E-1, T-1, etc. Another is called recipe "memory". You can "save" your current running memory into this recipe memory with different recipe names, or recall the recipe memory into the current running memory. In that case, the previous steps in running memory will be overwritten. **You cannot run the programming steps from the recipe "memory" directly.**

This controller can save up to 8 PID recipe (programs). Each recipe file can have up to 6 steps (C-1 to C-6). For convenience, we have pre-named these 8 pieces of recipe files as B1, B2, C1, C2, F1, F2, P1, and P2. These recipe files are all the same except their names, so you can store your special recipe to any of them. These recipes can be stored in the memory of the controller even when it is powered off. You can overwrite the exist recipe with a new one.

9.1 Save a Recipe

After the program has been entered, user can save this current program as a recipe for future use. Under the normal operating mode, press and hold SET key for 2 seconds until the bottom window shows "LOCK". The top window will show "0". Use the "▲" and "▼" key to adjust the value to "2" (the passcode for saving the program) and then press SET key to confirm. Then "SAVE" will be shown on the bottom window and "End" on top window. If press SET key now, you will exit this mode without overwriting any existing programs. Use "▲" and "▼" key to select the name of recipe to which you want to store the program. If you press "▲" (or "▼" key) repeatedly, you will see "End", "b1", "b2", "C1", "C2", "F1", "F2", "P1", "P2" one by one. Press the SET key again to store your current program under the selected recipe name. This process will overwrite the current recipe data to the saved recipe data. Figure 9 shows the flow chart of how to save a recipe.

9.2 Recall a Recipe

WARNING: Your current program will be overwritten by the selected recipe. Please write it down somewhere if it is important to you. To recall a recipe, press and hold SET key for 2 seconds until the bottom window shows "LOCK" and then release the SET key. The top window will show "0". Use "▲" key to adjust the number to "1" and then press SET. Then "rC" (recall) will be shown on the bottom window and "End" on top window. This can prevent your current program been accidentally overwritten by a recalled program. Use "▲" and "▼" key to locate recipe you want to recall. If you press "+" key repeatedly, you will see "End", "b1", "b2", "C1", "C2", "F1", "F2", "P1", and "P2" one by one. After you locate the recipe that you want to recall, press the SET key to select. Current program will be overwritten by the selected program. Figure 10 shows the flow chart of how to recall a recipe.

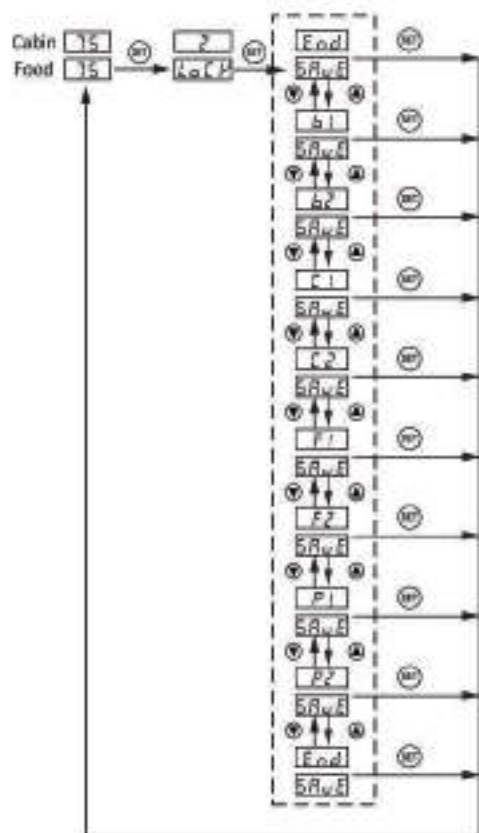

Figure 9. Flow chart of saving a recipe.

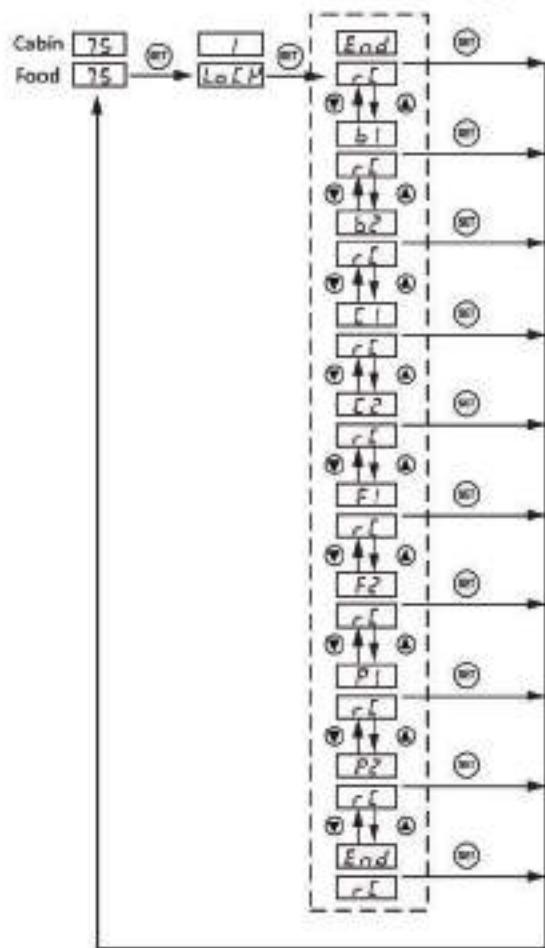

Figure 10. Flow chart of recalling a recipe.

10. Single-step Mode

In this mode, the controller will hold temperature at one set value (C-1) continuously as long as the controller is powered on. Even if the controller is powered off and turned on again, it will resume working in this mode. You do not need to enter any other program steps in this mode.

To enter the single-step mode, the user needs to set the parameter "PrG" to "OFF". Press and hold SET key for 2 seconds until LED display "LOCK" on the bottom window, and then release the SET key. The display on the top window will show "0". Use "▲" key to adjust the number to 3 and press SET key again to confirm. Then "PrG" will be shown on the bottom window, and "ON" or "OFF" in the top window. Use "▲" and "▼" key to toggle between "ON" and "OFF". Select "OFF" and press SET key for single-step mode. Otherwise, select "ON" and press SET key for program mode. The controller will go back to the normal operating mode. To set the temperature, press SET key once, and the bottom window will show "C-1". Use "▲" and "▼" key to adjust the temperature in the top window, then press SET to save and exit. Figure 11 shows the flow chart of how to switch to the single-step mode.

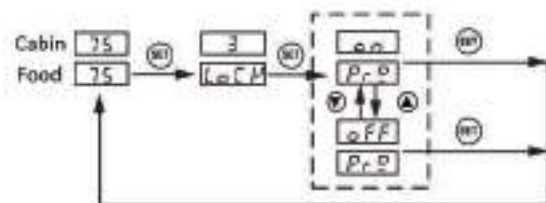

Figure 11. Single-step mode flow chart.

In single-step mode, the save and recall function (Section 9) can still work. But the change can only be applied to C-1, i.e., you can only store your current set temperature to the C-1 in a selected recipe, or recall the C-1 temperature from a selected recipe to the current set temperature. Other data will remain in the memory of controller but is not accessible under the single-step mode. To exit the single-step mode, you need to change the "PrG" value to "ON".

11. Programming Examples

a). Store your program as a recipe (Program Mode)

Before you input your program, check the PrG = ON (accessed by LCK code "3").

Press SET briefly, and enter the program below:

C-1 = 120, E-1 = t, t-1 = 120;

C-2 = 290, E-2 = F, F-2 = 160;

C-3 = 130, E-3 = t, F-3 = 300.

You can leave the rest of steps as their default values.

To store in program to recipe b1, long press SET key, set LCK = 2, choose b1, and press SET again to confirm and exit. Now the controller is back to the normal operating mode. It will run on this current program, which has just been saved as recipe b1.

b). Recall a recipe to the current program (Program Mode)

Before you input your program, check the PrG = ON (accessed by LCK code "3").

Long press SET, set LCK = 2, choose b1, press set to exit. Then recipe b1 is recalled back as the current program. The controller is back to the normal operating mode and will start run the current program.

c). Store your program as recipe (Single-step Mode)

Before you input your set temperature, check the PrG = OFF (accessed by LCK code "3"). Press SET key once, and then set C-1 = 150, press set again to confirm and exit. The controller will go back to the normal operating mode and start running on this single-step program.

To store current program back to recipe b2, long press SET, set LCK = 2, choose b2, press set to confirm and exit. Now your current program is stored as recipe b2.

d). Recall your recipe to current program (Single-step Mode)

Before you input your set temperature, check the PrG = OFF (accessed by LCK code "3"). Long press SET, set LCK = 1, choose b2, press set to confirm and exit. Now the C-1 from the recipe b2 is recalled back to your current program. The controller will start run at this temperature setting.

e). Advanced example.

This example will show you how the PrG mode can affect the saved and current recipe/program.

1) Set PrG = ON, select "b1" recipe:

C-1 = 120, E-1 = t, t-1 = 120;

C-2 = 290, E-2 = F, F-2 = 160;

C-3 = 130, E-3 = t, F-3 = 300

2) Change PrG = OFF, now the current single-step program is:

C-1: 120.

3) Set current C-1 to 200, then store current program back to recipe b1. Now the b1 recipe is:

C-1: 200.

4) Change PrG = ON, current b1 recipe is:

C-1 = 200, E-1 = t, F-1 = 120;

C-2 = 190, E-2 = F, F-2 = 160;

C-3 = 130, E-3 = t, F-3 = 300.

12. Factory Reset Function

WARNING! This function will restore all the parameters (including receipts in the memory) back to factory default. Please write all the necessary settings down in safe place.

To reset, under the normal operating mode, press and hold SET key for 2 seconds until LED display "LOCK" on the bottom window, and then release the SET key. The display on the top window will show "0". Use "+" key to adjust the number to 666 and press SET key again to confirm. The bottom display will show as "nif" and top display will show as "OFF". Press "▲" key once to change "OFF" to "ON". Then press SET key to confirm factory reset. Two displays will show "—" then "8.8.8.8". When you see this display back to normal operating mode, factory reset completed. Please check Figure 12 for reset flow chart.

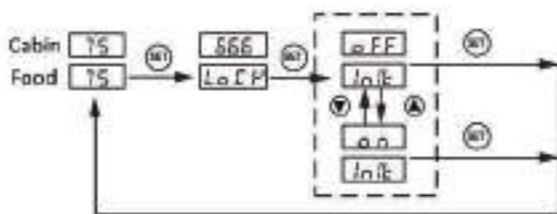
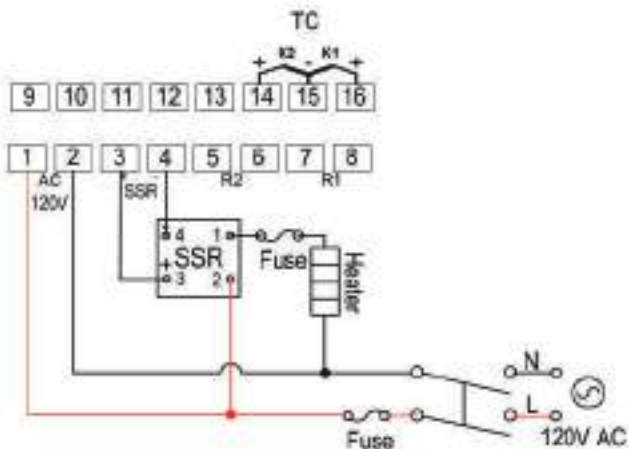

Figure 12. Flow chart of how to reset the controller. ON is to confirm, OFF is to cancel.

13. Wiring Examples

13.1 Basic wiring for a system with a heater (120 VAC) and type K thermocouple.



13.2 Basic wiring for a system with a heater (240 VAC) and PT1000 sensors.

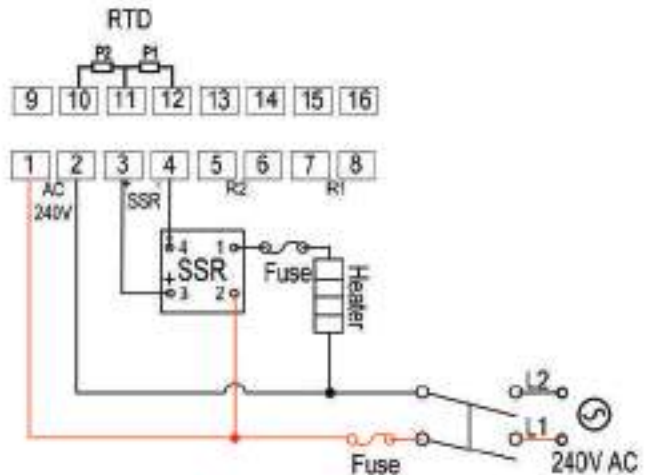

13.3 Wiring example

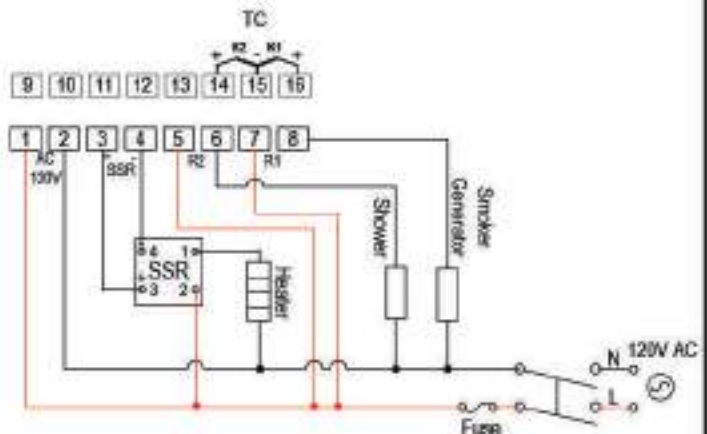

14. Error Message

-H-: This is an error message indicating sensor input error, either the sensor type is not set correctly or the input sensor signal is out-of-range. The common reasons that this error message is showing are:

- 1) The setting of sensor input parameter "Sn" doesn't match the sensor plugged in. For type K thermocouple, please set Sn to "K" (it looks like backwards "4"); for PT1000 RTD sensor, please set Sn to "Pt". Please see Table 3 in page 5 for details.
- 2) No sensor is connected in or the connection between the sensor and the controller is bad.
- 3) The sensor wires are shorted or open.

(End)