



40W

**VOLTAGE:** 120-277V **WATTS:** 40W

**SKU:** IL-4025FSG-120 Emergency Green LED

**SKU:** IL-4025GreenBB Emergency Green LED

**TECHNICAL SPECS**

Waterproof Rating	IP65 for Damp/Wet Conditions
PPF	64 $\mu\text{mol/s}$
Efficacy	1.6 $\mu\text{mol/J}$
LED Lifespan (90%)	55,000+ hours
Power Factor	$\geq .95$
Ambient Temperature	0 - 35°C / 32-95°F
Relative Humidity	98%
Frequency	50 / 60Hz
Heat Output	136 BTU/h
Min. Power Factor	0.9
Typical Power Consumption	40W in AC operation,
Typical Power Consumption	15W in Battery Backup operation
Emergency Function Time	1.5 hours

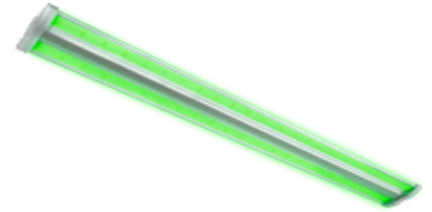

**ILW GREEN LED SPECTRUM**

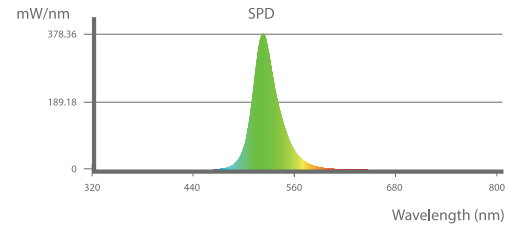

**FEATURES**

- Easy installation in new construction or retrofit
- Stainless steel mounting brackets are standard

**VOLTAGE AND AMPERAGE**

120V	0.32A	38W
208V	0.19A	39W
240V	0.18A	40W
277V	0.16A	41W

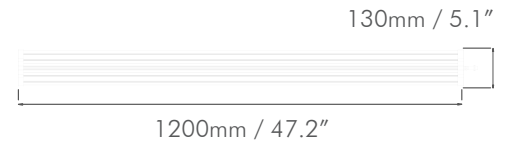

**iLW GREEN PHYSICAL SPECS**

Height	29mm / 1.14"
Width	130mm / 5"
Length	1200mm / 47.2"
Weight	1.3kg / 2.86 lbs

**BATTERY BACKUP PHYSICAL SPECS**

Height	72mm / 2.83"
Width	125mm / 4.92"
Length	505mm / 19.88"

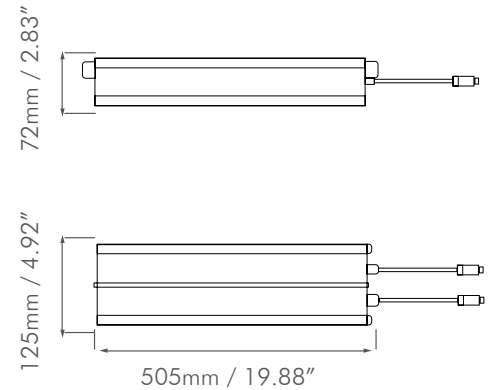

Any component that fails due to manufacturing defect is guaranteed for 5 years. The warranty does not cover physical damage, abuse or instances of uncontrollable natural forces. See the full ILUMINAR Lighting warranty document for detailed information.

iluminarlighting.com  
Toll Free: 1-877-540-5588



© Copyright 2024 ILUMINAR Lighting  
Subject to change without notice.