



# 1000W

## DE FIXTURE

# MH / HPS

**VOLTAGE:**

480V

**SKU WITH LAMP:**

ILUM-DE-1K480

**SKU NO LAMP INCLUDED:**

ILUM-DE-1K480-NL

### SPECIFICATIONS

Input Current	2.17A
Input Power	1032W
Main Voltage	480V
Voltage Range	432-505V
THD	<10%
Controller	0 -10V
Min Power Factor	>.99
Crest Factor	<1.7
Input Connection	IP67 Wieland Plug
Input Frequency	50 - 60Hz
BTU Output	4,400 btu
Relative Humidity	25-70% (Non-condensing)
Operation Temp.	0 - 35°C / 32-95°F
Recommended Lamp	1000W DE 400V
Lamp Included	ILUMINAR
Lamp Base	K12 x 30s
PPF	2100 μmol/s
Weight	6kg / 13.23lbs
Standalone Coverage	5'x4'
Minimum Mounting Height	1.2m / 4'
Width	9.80" / 249mm
Height	23.98" / 609mm
Length	11.02" / 280mm



### DIMENSIONS

249mm / 9.80"

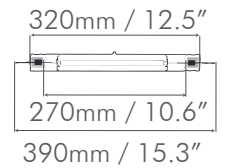
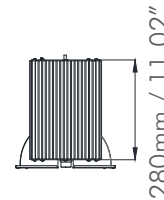
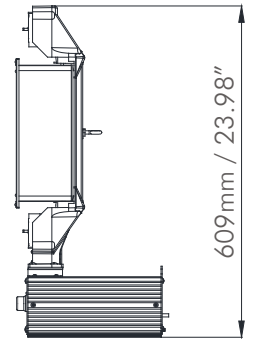
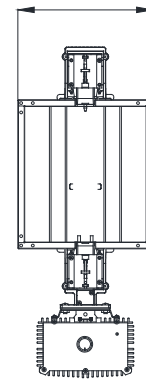

Recommended to use with ILUMINAR Touch+

### PROTECTIONS

- Microprocessor Driven
- End of Lamp Life (EOL)
- Open Circuit Protection
- Ignition Failure Protection
- Thermal Sensing Protection

### DE HPS SPECTRUM

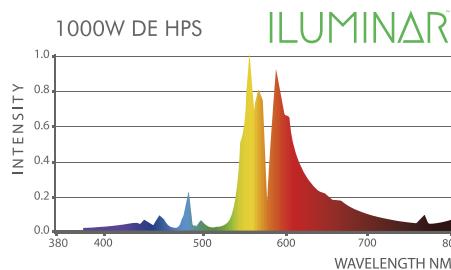
 View MH Compatible Lamp Spectra at [iluminarlighting.com](http://iluminarlighting.com)

### MOUNTING & COVERAGE

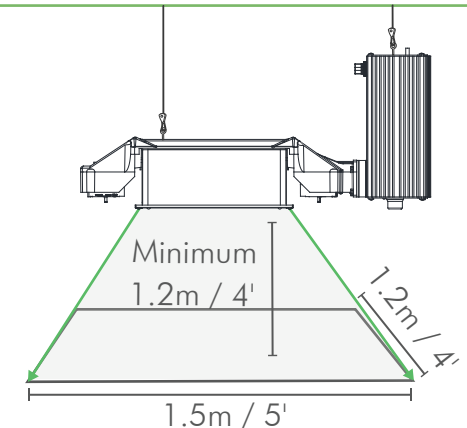

# 3 YEAR WARRANTY

 iluminarlighting.com  
 Toll Free: 1-877-540-5588

 © Copyright 2024 ILUMINAR Lighting  
 Subject to change without notice.